

DKK**دنده کار کرمان****Dandehkar Kerman Co.****Medium Drawing Machine****(with Annealler)****TECHNICAL SPESIFICATIONS**

Drawing Method	4 Horizontal Axis	
Speed	300-1100 (m/Min)	
Max. Wire Inlet Dia. (mm)	Ø3.2	
Min. Wire Outlet Dia. (mm)	Ø0.4	
Max. Number of Dies	17	
Elongation	NO. 1 to 16 : 25%	
	NO. 17 : 15.5%	
Motor Powers	Main	55 KW
	Spooler	15 KW
	Lubrication Unit	0.75 KW
	Traversing unit	0.75 KW
Max. Annealing Output Power	80 KVA	
Max. Annealing Current	1300 A	
Max. Annealing Voltage	60 V DC	
Steam Consumption	2Kg/hr (0.2Mpa)	
Machine Dimensions (mm)	Drawing Unit	2680L x 2000W x 1340H
	Spooler	1970L x 1320W x 1250H
	Annealer	1180L x 1600W x 2570H
	Dancer	1020L x 450W x 1650H
	Main Elec. Cabinet	1040L x 630W x 2030H
	Anneal Elec. cabinet	1020L x 920W x 2010H
Weight	7830 ± 10 Kg	

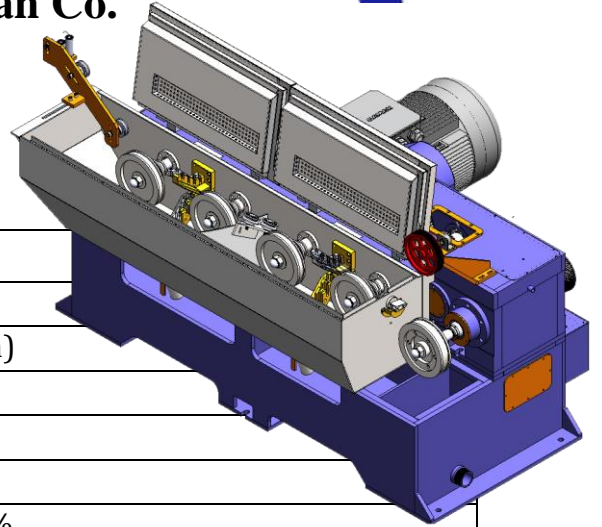
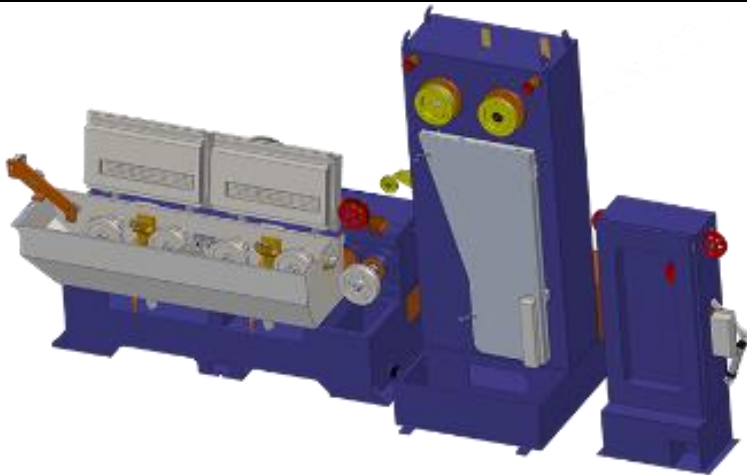

Address: No.16-Sonbol St. -Industrial Town No.1 Joupar Road -Kerman-IRAN

www.dandehkar.comE-Mail: Info@dandehkar.com

Tel: +98 034 33241001- 2

Fax: +98 034 33210912

Po. Box: 76351-68335